



L3016
ULTRA TABLE
46" slotted steel ADA picnic table,
3 flat bench seats with traditional
edge, levelers, portable mount

Material

The table is 46.25" square and features four flat bench seats. The table top and seats are 12-gauge slotted steel with .38" width slots and feature a traditional edge. Table top and seats are protected by Fusion Advantage™, a plastisol coating with an average .125" thickness and a high-gloss powder coat. The table also features a 1.50" diameter umbrella hole in the center. The table top is designed to support 100 lbs per square foot and the seats will support 200 lbs per linear foot.

The frame and legs are made of 2.38" O.D. steel tubing protected by a fade resistant powder coat finish featuring a state of the art primer proven to prevent rusting. The frame is portable in design allowing for flexibility in placement. The legs feature adjustable feet that allow for leveling and have predrilled holes for surface mounting to prevent movement (mounting hardware is not included).

Finish

Fusion Advantage is a heat fused plastisol coating that creates an impervious rustproof barrier and resists UV deterioration, mildew, staining and fading.

The finish has been tested to the requirements of ASTM E1354 and is determined to be in compliance with California Uniform Fire Code 1103.2.1.4.2.

A state of the art primer is applied to all of the under supports, providing extreme rust fighting protection and durability. Treated components exceed the industry standard by 34% in testing by independant sources.

Color

See website or sales representative for color choices.

Assembly

Table requires some assembly. Stainless steel assembly hardware is included.

Maintenance

The product is virtually maintenance-free and requires only periodic cleaning with a sponge and a solution of mild detergent and water to remove surface dirt. Do not clean with solvent or petroleum based products.

Accessories

8' Umbrella
 9' Umbrella

7LPU
 9LPU

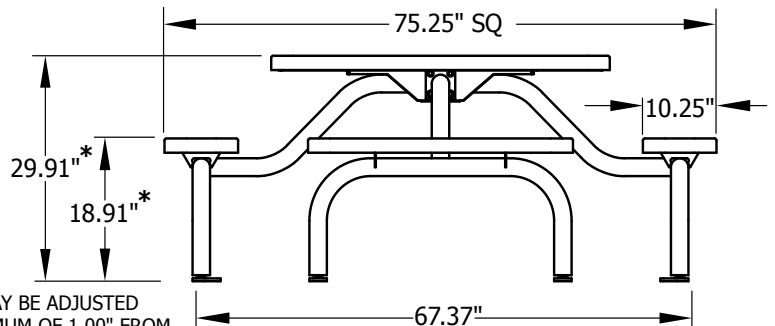
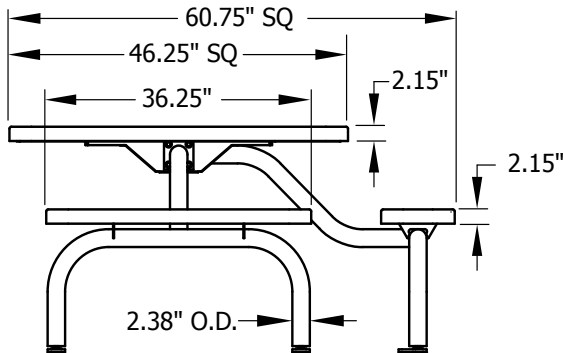

* LEVELERS MAY BE ADJUSTED OUT A MAXIMUM OF 1.00" FROM THE DIMENSION SHOWN.

Shipping Information

Unit Wt.	Unit Shipping Wt. UPS	Unit Shipping Wt. Truck (1+ Units)	Unit Ship Size w/Pallet	Max Units per Pallet	Pallet Wt. (48" x 48")	Total No. Pkgs	Shipping Class
231 lbs	N/A	257 lbs/unit	14 cu. ft.	2	50 lbs	3	150