



L1425
REFLECTIONS CONTOUR
BENCH
6' slotted steel contour bench,
portable/surface mount, diagonal
style design

Material

The contour bench seat is 72.25" long. The contour seat is made of 10-gauge slotted steel with .38" wide slots. The bench seat is protected by Fusion Advantage™, a plastisol coating with an average .125" thickness and a high-gloss powder coat. The bench seat will support 200 lbs per linear foot.

The legs are made of 1.5" square steel tubing, are protected by a fade resistant powder coat finish featuring a state of the art primer proven to prevent rusting. The bench is designed to be portable, allowing for flexibility in placement. Each leg also has a foot with a predrilled hole for surface mounting to prevent movement (mounting hardware is not included).

Finish

Fusion Advantage is a heat fused plastisol coating that creates an impervious rustproof barrier and resists UV deterioration, mildew, staining and fading.

The finish has been tested to the requirements of ASTM E1354 and is determined to be in compliance with California Uniform Fire Code 1103.2.1.4.2.

A state of the art primer is applied to all of the under supports, providing extreme rust fighting protection and durability. Treated components exceed the industry standard by 34% in testing by independant sources.

Color

See website or sales representative for color choices.

Assembly

The bench requires some assembly. Stainless steel assembly hardware is included.

Maintenance

The product is virtually maintenance-free and requires only periodic cleaning with a sponge and a solution of mild detergent and water to remove surface dirt. Do not clean with solvent or petroleum based products.

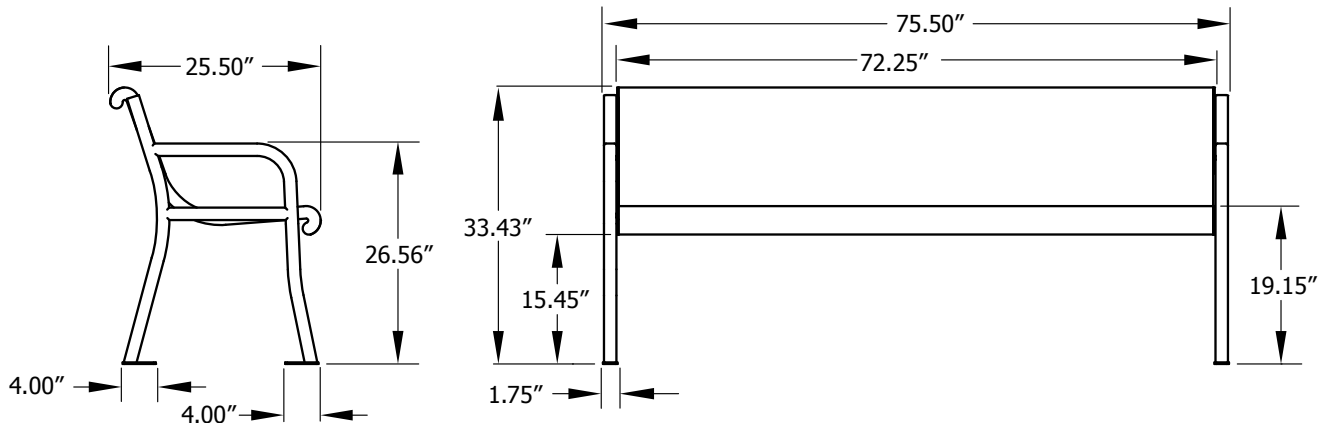

Shipping Information

Unit Wt.	Unit Shipping Wt. UPS	Unit Shipping Wt. Truck (1+ Units)	Unit Ship Size w/Pallet	Max Units per Pallet	Pallet Wt. (74" x 32")	Total No. Pkgs	Shipping Class
136 lbs	N/A	152 lbs/unit	30 cu. ft.	4	100 lbs	2	70