



F1193
PICNIC TABLE
46" diameter expanded steel, ADA compliant picnic table with 3 seats, traditional edge, in ground mount

Accessories

- 8' Umbrella **7LPU**
- 9' Umbrella **9LPU**

Material

The table is 46.25" in diameter and features three flat bench seats. The tabletop and seats are 3/4" #9 expanded steel with a diamond shape and feature a traditional edge. Tabletop and seats are protected by Fusion Advantage™, a plastisol coating with an average .125" thickness and a high-gloss powder coat. The table also features a 1.53" diameter umbrella hole in the center. The tabletop is designed to support 100 lbs per square foot and the seats will support 200 lbs per linear foot.

The seat supports are made of 2.38" O.D. steel tubing protected by a fade resistant powder coat finish featuring a state of the art primer proven to prevent rusting. The frame is 4" square tube, also with a fade resistant powder coat finish and state of the art primer. It is designed to be mounted 26.06" deep for a sturdy support. The table may be installed to an ADA compliant height by reducing the installation depth by 3.12". Refer to the note on the drawing below.

Finish

Fusion Advantage is a heat fused plastisol coating that creates an impervious rustproof barrier and resists UV deterioration, mildew, staining and fading. The finish has been tested to the requirements of ASTM E1354 and is determined to be in compliance with California Uniform Fire Code 1103.2.1.4.2.

A state of the art primer is applied to all of the under supports, providing extreme rust fighting protection and durability. Treated components exceed the industry standard by 34% in testing by independent sources.

Color

See website or sales representative for color choices.

Assembly

Table requires minor assembly. Stainless steel assembly hardware is included. In ground installation requires site preparation and construction of a temporary support.

Maintenance

The product is virtually maintenance-free and requires only periodic cleaning with a sponge and a solution of mild detergent and water to remove surface dirt. Do not clean with solvent or petroleum based products.

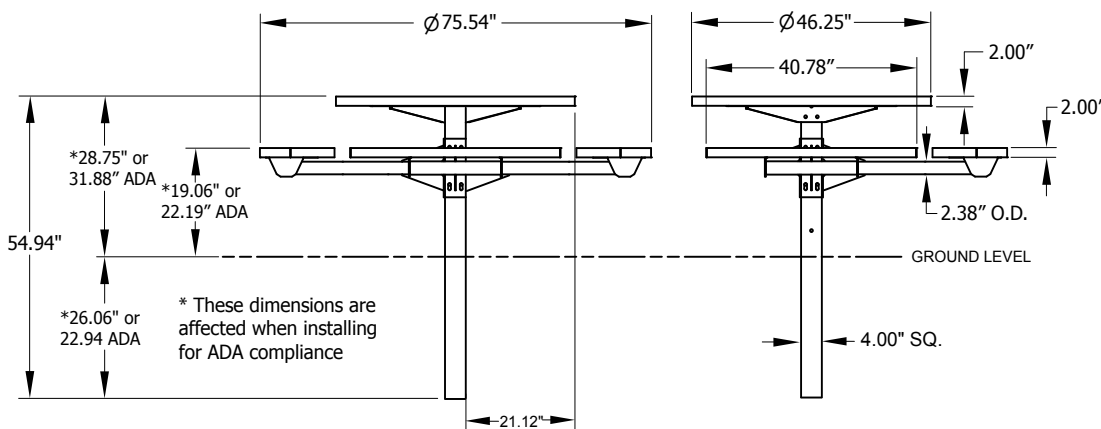

Shipping Information

Unit Wt.	Unit Shipping Wt. UPS	Unit Shipping Wt. Truck (1+ Units)	Unit Ship Size w/Pallet	Max Units per Pallet	Pallet Wt. (58" x 48")	Total No. Pkgs	Shipping Class
197 lbs	N/A	215 lbs/unit	45 cu. ft.	3	50 lbs	4	70