



## F1190M COURTYARD RECEPTACLE

22-gallon expanded steel  
receptacle with expanded steel flat  
top and liner

### Replacement Parts

Flat Steel Lid	<b>F1195</b>
Black Plastic Liner	<b>F1014</b>

### Accessories

Trad. Inground Mount	<b>F1094</b>
Trad. Surface Mount	<b>F1098</b>
45° Surface Mount	<b>F1406</b>
45° Inground Mount	<b>F1407</b>
Corkscrew Anchor	<b>A1020</b>

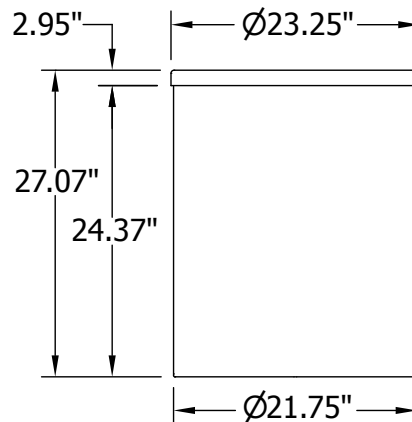

SIDE VIEW

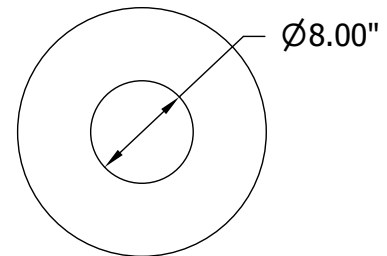

TOP VIEW

### Material

The 22-gallon receptacle body is made of 3/4 #9 expanded steel with a diamond pattern. The receptacle and top are protected by Fusion Advantage™, a plastisol coating with an average .125" thickness and a high-gloss powder coat.

The expanded steel flat top is made of 14-gauge steel and features a 8" diameter center opening for easy waste disposal. The top lifts off for easy trash removal and a security chain is included.

The reusable 22-gallon plastic liner is made of black high-density polyethylene.

### Options and Accessories

Optional mounting kits for various applications are available.

### Finish

Fusion Advantage is a heat fused plastisol coating that creates an impervious rustproof barrier and resists UV deterioration, mildew, staining and fading.

The finish has been tested to the requirements of ASTM E1354 and is determined to be in compliance with California Uniform Fire Code 1103.2.1.4.2.

### Color

See website or sales representative for color choices.

### Assembly

Mounting options require some assembly, if purchased.

### Maintenance

The product is virtually maintenance-free and requires only periodic cleaning with a sponge and a solution of mild detergent and water to remove surface dirt. Do not clean with solvent or petroleum based products.

### Warranty

20-year limited structural warranty with 7-year finish warranty from the date of purchase. See full details on multi-year warranties for components at [www.anovafurnishings.com/warranty.aspx](http://www.anovafurnishings.com/warranty.aspx).

### Shipping Information

Unit Wt.	Unit Shipping Wt. UPS (1-2 Unit)	Unit Shipping Wt. Truck (3+ Units)	Unit Ship Size w/Pallet	Max Units per Pallet	Pallet Wt. (48" x 48")	Total No. Pkgs	Shipping Class
78 lbs	147 lbs/unit	85 lbs/unit	32 cu. ft.	12	50 lbs	1	100