



**D6004**  
**RALLY RECEPTACLE**  
32-gallon plastisol coated,  
perforated steel receptacle with  
liner and spun steel top

**Replacement Parts**

Black Plastic Liner **F1017**  
Contour Top **F3005**

**Accessories**

Traditional In ground Mount **F1094**  
Traditional Surface Mount **F1098**  
45° Roadside In ground Mount **F1407**  
45° Roadside Surface Mount **F1406**  
Corkscrew Anchor **A1020**

**Material**

The 32-gallon receptacle body is made of 14-gauge perforated steel with a .31" diameter uniform hole pattern. The receptacle is protected by Fusion Advantage™, a plastisol coating with an average .125" thickness and a high-gloss powder coat. The top is made of 18-gauge galvanized spun steel and is protected by a fade resistant powder coat finish featuring a state of the art primer proven to prevent rusting. The top features a 10" diameter opening for easy trash disposal and includes a 14" web security strap.

**Finish**

Fusion Advantage is a heat fused plastisol coating that creates an impervious rustproof barrier and resists UV deterioration, mildew, staining and fading.

The finish has been tested to the requirements of ASTM E1354 and is determined to be in compliance with California Uniform Fire Code 1103.2.1.4.2.

**Color**

See website or sales representative for color choices.

**Assembly**

Attaching the top and security strap to the receptacle body requires some assembly. Purchase of mounting options may require additional assembly.

**Maintenance**

The product is virtually maintenance-free and requires only periodic cleaning with a sponge and a solution of mild detergent and water to remove surface dirt. Do not clean with solvent or petroleum based products.

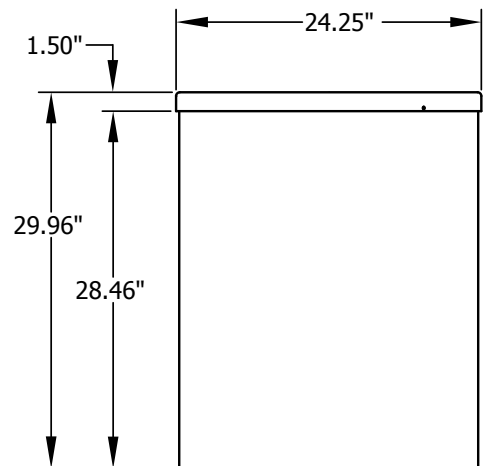
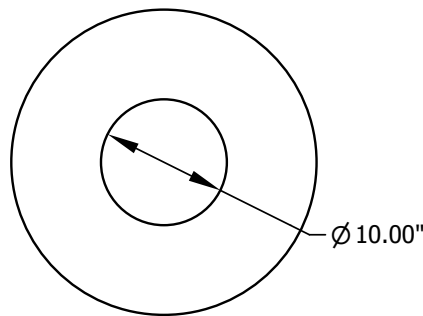

**Shipping Information**

Unit Wt.	Unit Shipping Wt. UPS (1-2 units)	Unit Shipping Wt. Truck (3+ units)	Unit Ship Size w/Pallet	Max Units per Pallet	Pallet Wt. (48" x 32")	Total No. Pkgs	Shipping Class
66 lbs	110 lbs/unit	75 lbs/unit	32 cu. ft.	8	50 lbs	2	150